

Predictors of Women's Exercise Behavior Based on Developed Theory of Planned Behavior with Action and Coping Planning

**Zeinab Gholamnia Shirvani¹, Fazlollah Ghofranipour^{2*},
Reza Gharakhanlou³, Anoshirvan Kazemnejad⁴**

Received: 20/07/2014

Accepted: 24/09/2014

Abstract

Aim: Level of physical activity as key determinant of healthy lifestyle is less than what is required in individuals particularly women. Applying theories of behavioral change about complex behaviors such as physical activity leads to identify effective factors and their relations. The aim of this study was to determine predictors of exercise behavior based on developed Theory of Planned Behavior with planning constructs in military personnel's wives.

Methods: We performed this cross-sectional study on 150 military personnel's spouses residing in organizational houses, in Tehran, Iran in 2013. The participants were randomly selected with multi-stage cluster sampling. The validity and reliability of developed scale were evaluated before conducting the path analysis. Data were analyzed using SPSS.16 and LISREL8.8.

Finding: The developed model predicted 48, 11, 12 and 35 percent of the variance in intention, action planning, coping planning and behavior, respectively. Subjective norms (Beta=0.35, $p<0.01$) and perceived behavioral control (Beta=0.28, $p<0.01$) were the predictors of intention. Determinants of behavior included action planning (Beta=0.40, $p<0.01$), coping planning (Beta=0.39, $p<0.01$), intention (Beta=0.23, $p<0.01$) and subjective norms (Beta=0.08, $p<0.01$). Instrumental and affective attitude had no significant path coefficient to dependent variables. The path of perceived behavioral control to behavior was non-significant. The developed theory fitted to data better than the original theory.

Conclusion: This research demonstrated relative weights and relationships of Theory of Planned Behavior constructs with action and coping planning in physical activity behavior of military staffs' spouses. It is essential to consider these effective factors in designing of health education programs.

Key words: Action planning, Coping planning, Path analysis, Physical activity, Theory of Planned Behavior

1. Ph.D. Candidate, Department of Health Education & Health Promotion, Faculty of Medical Sciences, Tarbiat Modares University, Tehran, Iran Email: zeinab.gholamnia@modares.ac.ir

2. Associate Professor, Department of Health Education & Health Promotion, Faculty of Medical Sciences, Tarbiat Modares University, Tehran, Iran Email: ghofranf@modares.ac.ir

3. Associate Professor, Department of Physical Education & Sport, Faculty of Humanities, Tarbiat Modares University, Tehran, Iran Email: ghara_re@modares.ac.ir

4. Professor, Department of Biostatistics, Faculty of Medical Sciences, Tarbiat Modares University, Tehran, Iran Email: kazem_an@modares.ac.ir

Intruduction

Physical inactivity is a major contributor to non-communicable diseases, such as heart disease, diabetes and cancer [1]. Inactivity rises with age, is higher in women than men [2]. The Eastern Mediterranean Region has one of the highest rates of physically inactive people in the world. One in three men and one in two women do not follow the minimum recommended levels for physical activity [1]. Report of the health ministry and medical education indicates above 60 percent of Iranian housewives are sedentary [3]. Health indicators of Iran shows that only 27 percent of 35-44 years old women are physically active at least 10 minutes in leisure time in Tehran [4]. Also, research priorities of a medical sciences university points to low level of activity in military staffs' spouses in Tehran.

Given the complexity of exercise behavior, it is necessary to use behavior change theories and models to identify the main factors influencing the behavior and relationships between them and key elements of interventions [5]. The Theory of Planned Behavior (TPB) [6] is one of the leading theories applied to predict a range of health behaviors, such as physical activity [7, 8]. TPB theorizes that behavioral intention (a conscious motivation to act) is the primary determinant of any given behavior that is influenced by attitudes toward the behavior

(positive and/or negative evaluations of performance), subjective norms (perceptions of social norms to act) and perceived behavioral control (perceptions of controllability and ease of performance) [9]. TPB has been found to typically explain 41-46% of the variance in physical activity intentions and 24-36% of the variance in behavior [10]. However the TPB suggests that a positive intention is enough for exercise behavior to happen, recent summary evidence has showed that intentional control of (physical activity) behavior is more limited than supposed in the TPB [10-12]. Physical activity intentions can't explain more than half of the variance in behavior [10, 13]. This discrepancy between intention and behavior is referred to as "the intention-behavior gap" [12]. Ahmadi et al. study indicated that educational Intervention based on TPB, despite a significant increase in the intention score, had no effect on physical activity behavior [14]. This may be due to failure to translate intention into behavior. Applying post-intentional factors can bridge this gap and result in better physical activity interventions [9]. Abroad of Iran, Previous studies have found that Planning is one of the important post intentional factors in health behaviors [15, 16] (for example physical activity [17, 18] that can bridge between intention and behavior. Planning can be subdivided into two aspects: action planning

and coping planning [19]. Action planning is an extension of an intention formation including specific situation parameters and a sequence of action [20]. People are more likely to translate their good intentions into physical activity when they plan when, where, and how to perform the desired physical activity [21, 22]. Coping planning is the anticipation of barriers and generation of strategies to overcome them [23]. People imagine scenarios that hinder them in performing their intended behavior, and they develop one or more plans to cope with such a challenging situation. Previous research suggests that action planning and coping planning have a synergistic effect on physical activity [24]. To our best knowledge, there was no study about predictors of physical activity behavior based on TPB along with planning in Iran. Also no researcher has investigated whether extended TPB model with planning can explain more of the behavior variance or not. On the other hand, no (theory- based) survey had performed as respects physical activity behavior in military personnel's spouses in Iran. Health and health behavior of these women are key determinants of military families' health (similar to other families in the society). Also occupational success of military staff and important role to ensure country security depends on their living in healthy families [25]. Accordingly, current research was carried out to

some reasons; a: prevalence of inactivity in Iranian women such as military staff's wives; b: effective role of developed TPB with planning to promote and maintain of physical activity behavior; c: lack of research in examining of exercise behavior and its determinants in aforesaid target group. The purpose of this study was to identify predictors of exercise behavior based on extended TPB with action and coping planning in military personnel's wives in Tehran.

Methods

We implemented a cross-sectional study utilizing the path analysis in 150 military personnel's spouses residing in organizational towns, in Tehran, Iran in 2013. Path analysis is a straightforward extension of multiple regression. Its aim is to provide estimates of the magnitude and significance of hypothesized causal connections between sets of variables [26]. Nunnally and Bernstein [27] in the regression discussion mentioned for each predictor, at least 10 participants are required in order to hope to have a stable predictive equation. We selected participants with randomly multi-stage cluster sampling. In this method, we assigned randomly two organizational towns among list of organizational towns in Tehran. Then we allocated randomly a number of the buildings (consisted of several houses) amongst these

organizational towns. Finally, a number of the houses were randomly chosen in selective buildings. The inclusion criteria were: aged between 18 - 64 years old, being literate, wish to participate, not currently being investigated by other researchers, no history of chronic conditions, mental and disabling disorders. The exclusion criteria included to have medical contraindications for exercising. Data were collected by health education researchers.

In order to constructing the developed TPB scale, we generated an item pool extracted from the TPB, action and coping planning literature [9, 28-32] especially Ghazanfari et al. study [33]. As well as, Ajzen [34] and Francis et al. manual [35] were used in making of questionnaire. Banville et al. [36] method was employed to cross culturally translate of this scale. Two independent bilingual health researchers translated the original version to Persian. Both translators were asked to aim for conceptual rather than literal translation. Blind to the original version, the other two bilingual health researchers translated Persian version to English. Eventually, an expert team comprising the translators, the researchers and one specialist in psychometrics reviewed all the translation and cultural adaptation processes. Agreement in terms of semantic, idiomatic and conceptual equivalence was reached and a final version of the questionnaire was provided [37].

The psychometric evaluation of developed TPB scale in two separate samples of target women was explained in detail in the other paper. therefore current paper briefly presented methods and results of aforesaid study in order to inform readers.

An expert panel of 10 specialists evaluated grammar, wording, item allocation and scaling of the developed TPB questionnaire (qualitative method). In the quantitative phase, we calculated two indicators: the content validity index (CVI) and the content validity ratio (CVR). CVI assesses the relevancy, simplicity and clarity of an item to the content represented in an instrument [38, 39]. CVI was calculated as the proportion of items that received a rating of 3 or 4 by the experts [40]. Polite and Beck recommended 0.80 for the acceptable lower limit for CVI value [41]. CVR examines the essentiality of an item in an instrument. For calculating this index the experts rate each item as essential, useful but not essential, or not essential [42]. Face validity was evaluated by qualitative and quantitative methods: In the qualitative stage, 10 women (of target group) were asked to evaluate the scale and indicate if they felt difficulty, Irrelevancy or ambiguity in responding to the questionnaire. In the quantitative phase, we calculated the impact score (frequency \times importance) to indicate the percentage of women who identified the item

was important or quite important. Those items associated with an impact score equal or greater than 1.5 were considered appropriate [43]. We used internal consistency and test-retest reliability methods to assess the reliability of scale. The internal consistency with the Cronbach's alpha coefficient was examined in 30 women. The alpha values of 0.70 or above were considered satisfactory [44]. We estimated the stability (test-retest reliability) of the developed instrument by intraclass correlation coefficient (ICC) [45]. Women (n=30) completed the questionnaire twice with a 2-week interval. We specified the construct validity of this scale by administering exploratory factor analysis (EFA) and confirmatory factor analysis (CFA). We accomplished EFA utilizing the principal component analysis (PCA) and varimax rotation. To determine the best structure, the eigenvalue greater than one and factor loading equal to or greater than 0.4 were applied [46]. We conducted CFA by means of maximum likelihood estimation. The extended questionnaire included affective attitude (refers to emotions drives engendered by the prospect of performing a behavior) [47], instrumental attitude (which refers to a more cognitive consideration of the extent to which performing a behavior would be advantageous) [47], subjective norms, perceived behavioral control,

intention, action planning, coping planning and behavior. Each structure comprised of three items with five- point Likert responses.

In the path analysis stage, we assessed the developed model's fit applying many fit indices; chi square (χ^2) should be non-significant to indicate a good fit [48]. $\chi^2/df < 3$ [49], Root Mean Square Error of Approximation (RMSEA) $\leq .06$, Root Mean Square Residual (RMSR) $\leq .08$ [48] and Comparative Fit Index (CFI), Goodness of Fit Index (GFI), Adjusted Goodness of Fit Index (AGFI), Normed Fit Index (NFI), Non- Normed Fit Index (NNFI) and Incremental Fit Index (IFI) $\geq .90$ [49] show a good fit. The Ethics Committee of Tarbiat Modares University approved this study. All participants gave their permission by signing an informed consent form. We analyzed the data through SPSS16 and LISREL8.8 by utilizing the Cronbach's alpha coefficient, intraclass correlation coefficient, principal component analysis with varimax rotation, maximum likelihood estimation, covariance matrix, correlation matrix and standardized regression coefficients (β).

Results

The results of psychometric assessment of the developed TPB scale were satisfactory. CVI, CVR, impact score, alpha Cronbach and ICC for the questionnaire were 0.86, 0.83, 4.64, 0.90 and 0.77, respectively. An eight-factor

solution emerged as a result of an EFA and explained 76.33 percent of the variance observed. CFA results confirmed the exploratory eight factor structure ($\chi^2=378.68$, $df=239$, $\chi^2/df=1.58$, CFI=0.92, RMSEA=0.06). A total of 150 women (age mean= 31.18±5.33) participated in the path analysis study. 51.3 percent of women had academic education and 82 percent were housekeeper. 96 percent of these women were inactive or less active. Demographic characteristics and physical activity rate and level of the participants are shown in Table 1. The findings indicated the expanded TPB explained 48, 11, 12 and 35 percent of variance in the intention, action

planning, coping planning and behavior, in the order given (figure 1). The original TPB accounted for 48 and 13 percent of the intention and behavior variance (figure 2). Subjective norms ($\beta=0.35$) and perceived behavioral control ($\beta=0.28$) were the significant predictors of intention ($P<0.01$). Action planning ($\beta=0.40$), coping planning ($\beta=0.39$), intention ($\beta=0.23$) and subjective norms ($\beta=0.08$) were the determinants of physical activity behavior ($P<0.01$). Instrumental and affective attitude had no significant path to dependent variables. The path of perceived behavioral control to behavior was non-significant (Table 2). Fit indices displayed that the developed TPB fitted to data better than the original theory (Table 3).

Table 1 Demographic characteristics and physical activity rate/ level of the participants (organizational towns, 2013, n = 150)

Variable	Mean± SD	N (%)
Age (years)	31.18 ± 5.33	-
Number of children	2.30 ± 0.73	-
Number of family members	4.32 ± 0.74	-
Physical activity		
Day (s) per week	0.96 ±1.15	-
Minutes per week	28.80 ±3.47	-
Education		
Secondary/ College	-	73 (48.7)
University	-	77 (51.3)
Education of husband		
Secondary/ College	-	45 (30)
University	-	105 (70)
Occupation		
Housewife	-	123 (82)
Employed	-	27 (18)
Physical activity		
Inactive (0 Minutes per week)	-	60 (40)
Less active (<150 Minutes per week)	-	84 (56)
Active (≥150 Minutes per week)	-	6 (4)

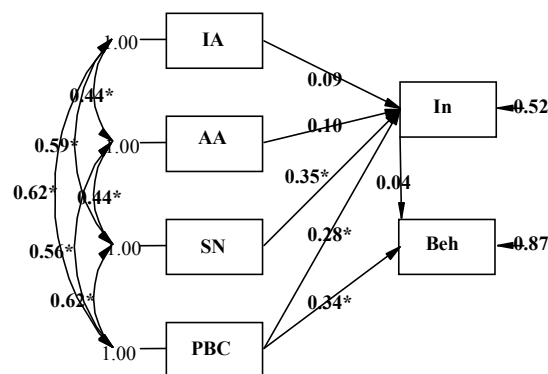
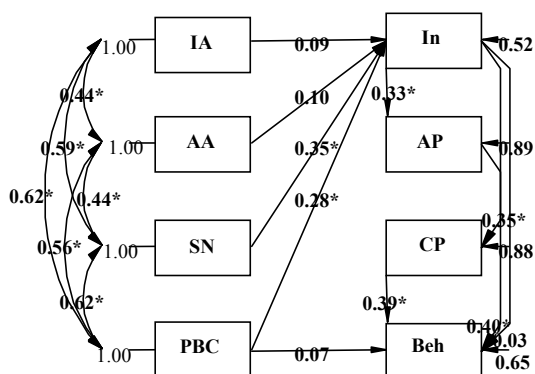

Figure 1 Path diagram of the developed TPB; * P<0.01

Figure 2 Path diagram of the TPB; * P<0.01

Constructs: IA: Instrumental Attitude, AA: Affective Attitude, SN: Subjective Norms, PBC: Perceived Behavioral Control, In: Intention, AP: Action Planning, CP: Coping Planning, Beh: Behavior

Table 2 Direct, indirect and total effects of developed TPB structures

Independent Variables	Dependent Variables	Direct Effects	Indirect Effects	Total Effects
Instrumental Attitude	Behavioral Intention	0.09	-	0.09
Affective Attitude		0.10	-	0.10
Subjective Norms		0.35*	-	0.35*
Perceived Behavioral Control		0.28*	-	0.28*
Instrumental Attitude	Action Planning	-	0.03	0.03
Affective Attitude		-	0.03	0.03
Subjective Norms		-	0.12*	0.12*
Perceived Behavioral Control		-	0.09*	0.09*
Behavioral Intention	Coping Planning	0.33*	-	0.33*
Instrumental Attitude		-	0.03	0.03
Affective Attitude		-	0.03	0.03
Subjective Norms		-	0.12*	0.12*
Perceived Behavioral Control	Behavior	-	0.10*	0.10*
Behavioral Intention		0.35*	-	0.35*
Instrumental Attitude		-	0.02	0.02
Affective Attitude		-	0.02	0.02
Subjective Norms	-	0.08*	0.08*	
Perceived Behavioral Control	Behavior	0.07	0.07	0.14
Behavioral Intention		-0.03	0.27*	0.23*
Action Planning		0.40*	-	0.40*
Coping Planning		0.39*	-	0.39*

* P<0.01

Table 3 Fit indices of TPB and developed TPB models

Fit index / Model	χ^2 *	df	χ^2/df	CFI	GFI	AGFI	NFI	NNFI	IFI	RMSEA	SRMR
TPB	13.38	12	1.11	0.91	0.98	0.93	0.73	0.80	0.95	0.02	0.04
Developed TPB	4.33	3	1.44	1.00	0.99	0.93	0.99	0.98	1.00	0.05	0.02

* P>0.05

Discussion & Conclusion

This survey was the first to ascertain the predictors of women's exercise behavior based on developed TPB with action and coping planning in Iran. It was also the first research to evaluate physical activity behavior and its determinants in military personnel's wives. It is of great importance to recognize the relevant and effective factors on physical activity of different groups for administering the efficient educational interventions [50]. Despite the lack of early access to exercise behavior statistics of military staff's spouses, this investigation demonstrated that only four percent of these women were adequately active. Therefore it was required to examine the physical activity behavior in this target group. The extended TPB scale was confirmed in term of content, face, construct validity and reliability. The path analysis findings demonstrated the TPB variables explained 48 and 13 percent of the variance in exercise intention and behavior. Whereas the developed model with planning predicted an additional 23% of variance in behavior. Also Scholz et al. study showed Inclusion of the two planning factors accounted for substantially more behaviour variance than intention alone did (22). De Bruin et al. survey in Netherland displayed that self-regulatory processes explained an additional 11 percent of variance of intensive

exercise behavior in working age people [51]. In fact, planning as a self regulatory strategy is important to predict of intentional behaviors such as physical activity [52].

Subjective norms and perceived behavioral control (PBC) predicted significantly intention. Blue [53], Omondi et al. [54] and Didarloo et al. [55] studies on diabetic patients revealed that subjective norms as an important determinant of exercise intention. However, some researchers noted subjective norms as a weak predictor of intention than attitude and perceived behavioral control [56, 57]. As regards PBC in the original TPB, similarly Hosseini et al. found it was positively related with exercise intention and behavior in female students [58]. Although PBC had no significant path to behavior in the developed model in present study. Perhaps to entry of planning variables in the TPB resulted to translate intention to behavior and there was no need for PBC. In contrast to this result, PBC had no significant effect to exercise intention of diabetic women in Ghazanfari [59] research whereas it was directly predicted behavior. Perhaps because of applying no constructs of planning in the patients, PBC could influence on the exercise behavior. Also Estabrooks and Carron [60] concluded control beliefs were good predictors of exercise attendance in the elderly.

In current research, intention explained no variance of behavior in the original TPB. These findings compatible with Prapavessis et al. [61] study on cardiac patient's exercise. In the developed TPB, Intention was the most powerful predictor of action and coping planning. Intention predicted indirectly behavior via planning. In other word, planning constructs mediated intention-behavior relation. Action planning, coping planning, intention and subjective norms predicted behavior, respectively. These findings were consist with the pakpour [62] results. Thus, planning could bridge intention- behavior gap in current path analysis. Similarly, Conner et al. suggested action planning mediates intention-exercise behavior relationships in students, particularly when exercise intentions are strong [63].

Instrumental and affective attitude had no significant path to intention and behavior. However, these structures correlated significantly to subjective norms and PBC. This result was supported by Prapavessis et al. [61] research. But Hagger et al. mentioned attitude was the strongest predictors of intention in the most studies based on Theory of Reasoned Action (TRA) and TPB as to physical activity behavior [64]. Perhaps perceived social pressure and sense of control over behavior in the subjects played much

more role than attitude in current research. For example, Biddle and Nigg reported PBC and subjective norms are more important than attitude as age rises [65].

Generally, some different results of this research with other studies may be related to assess different health behaviors in individuals with diverse socio-cultural characteristics. As Fishbein and Ajzen suggested it is possible to be various relative weights of subjective norms, attitudes and PBC to predict intention and behavior in different communities and people [66].

In all, we evaluated affecting factors to physical activity behavior and their relationships according to the TPB and planning constructs in the present study. Planning can bridge exercise intention-behavior gap in investigations based on the TPB. These efficient determinants of physical activity based on developed TPB should be considered to design health education interventions.

Ultimately, it should be noted that the study of military personnel's wives who resided in organizational town in Tehran may limit generalization of the findings to the entire military personnel's wives in Iran. Therefore, the results of this study have to be interpreted with some caution. Further studies are now needed with regard to larger samples,

including military staff's wives in the other areas. Also it is suggested to evaluate effect of an educational intervention based on extended TPB with planning in this target group by applying findings of present study.

Acknowledgement

This study was a part of dissertation for receiving PhD degree in Health Education that was supported by Faculty of Medical Sciences, Tarbiat Modares University, Tehran, Iran. We appreciate this institution. We are grateful to the kind assistance of the Dr. Armin Zareian, Mrs Roshandel, Mrs Amiri, Mr Bayati, Mrs Ghasemi and all people who kindly helped us in conducting this research.

Conflict of Interest Statement

The authors have no conflicts of interest.

Funding/ Support

This research was funded by Tarbiat Modares University.

References

- [1] World Health Organization. Health education and promotion. World Day for Physical Activity 2014. Available from: <http://www.emro.who.int/health-education/hed-events/world-day-for-physical-activity-2014.html>.
- [2] Hallal PC, Andersen LB, Bull FC, Guthold R, Haskell W, Ekelund U. Global physical activity levels: surveillance progress, pitfalls, and prospects. *The Lancet* 2012; 380(9838): 247-57.
- [3] Salamat Magazine. Healthy community. 60% of housewives are sedentary. 2010. Available from: http://www.salamatiran.com/pdf/salamat/309_2.pdf.
- [4] Delavari A, Alikhani S, Alaeddini F. The report of no communicable diseases risk factors in Islamic Republic of Iran. Ministry of Health and Medical Education. Health Chancellor. Center for Disease Control Tehran: Seda, 2005.
- [5] Nutbeam D, Harris E, Wise W. Theory in a nutshell: a practical guide to health promotion theories. Sydney, Australia: McGraw-Hill, 2010.
- [6] Ajzen I. The theory of planned behavior. *Organ Behav Hum Dec* 1991; 50(2): 179-211.
- [7] Armitage C. Can the theory of planned behavior predict the maintenance of physical activity. *Health Psychol* 2005; 24(3): 235-45.
- [8] Eng JJ, Martin Ginis KA. Using the theory of planned behavior to predict leisure time physical activity among people with chronic kidney disease. *Rehabil Psychol* 2007; 52(4): 435-42.

- [9] De Bruijn G-J, Rhodes RE, van Osch L. Does action planning moderate the intention-habit interaction in the exercise domain? A three-way interaction analysis investigation. *J Behav Med* 2012; 35(5): 509-19.
- [10] McEachan RRC, Conner M, Taylor NJ, Lawton RJ. Prospective prediction of health-related behaviours with the theory of planned behaviour: A meta-analysis. *Health Psychol Rev* 2011; 5(2): 97-144.
- [11] Hagger MS, Chatzisarantis NL. Integrating the theory of planned behaviour and self-determination theory in health behaviour: A meta-analysis. *Brit J Health Psych* 2009; 14(2): 275-302.
- [12] Webb TL, Sheeran P. Does changing behavioral intentions engender behavior change? A meta-analysis of the experimental evidence. *Psychol Bull* 2006; 132(2): 249-68.
- [13] Symons Downs D, Hausenblas H. Exercise behavior and the theories of reasoned action and planned behavior: A meta-analytic update. *J Phys Act Health* 2005; 2(1): 76-97.
- [14] Ahmadi Tabatabaei S, Taghdisi M, Nakhaei N, Balali F. Effect of educational intervention based on the theory of planned behaviour on the physical activities of Kerman Health Center's Staff (2008). *JBUMS* 2010; 12(2): 62-9.
- [15] Luszczynska A, Sobczyk A, Abraham C. Planning to lose weight: randomized controlled trial of an implementation intention prompt to enhance weight reduction among overweight and obese women. *Health Psychol* 2007; 26(4): 507-12.
- [16] Gollwitzer P, Sheeran P. Implementation intentions and goal achievement: A meta-analysis of effects and processes. *Adv Exp Soc Psychol* 2006; 38: 69-119.
- [17] Luszczynska A. An implementation intentions intervention, the use of a planning strategy, and physical activity after myocardial infarction. *Soc Sci Med* 2006; 62(4): 900-8.
- [18] Schwarzer R, Luszczynska A, Ziegelmann J, Scholz U, Lippke S. Social-cognitive predictors of physical exercise adherence: three longitudinal studies in rehabilitation. *Health Psychol* 2008; 27(1 Suppl): S54-63.
- [19] Reuter T, Ziegelmann JP, Wiedemann AU, Lippke S, Schüz B, Aiken LS. Planning bridges the intention-behaviour gap: Age makes a difference and strategy use explains why. *Psychol Health* 2010; 25(7): 873-87.
- [20] Abraham C, Michie S. A taxonomy of behavior change techniques used in interventions. *Health Psychol* 2008; 27(3):

- 379-87.
- [21] Wiedemann AU, Schüz B, Sniehotta F, Scholz U, Schwarzer R. Disentangling the relation between intentions, planning, and behaviour: A moderated mediation analysis. *Psychol Health* 2009; 24(1): 67-79.
- [22] Scholz U, Schüz B, Ziegelmann JP, Lippke S, Schwarzer R. Beyond behavioural intentions: Planning mediates between intentions and physical activity. *Brit J Health Psych* 2008; 13(3): 479-94.
- [23] Sniehotta FF. Towards a theory of intentional behaviour change: Plans, planning, and self-regulation. *Brit J Health Psych* 2009; 14(2): 261-73.
- [24] Araújo-Soares V, McIntyre T, Sniehotta FF. Predicting changes in physical activity among adolescents: the role of self-efficacy, intention, action planning and coping planning. *Health Educ Res* 2009; 24(1): 128-39.
- [25] Ahmadi M, Fathi Ashtiani A, Habibi M. Psychological health in military pilots' families. *JBS* 2009; 2(4): 305-8.
- [26] Lleras C. Path analysis. *Enc Soc Measure* 2005; 3: 25-30.
- [27] Nunnally J, Bernstein I. *Psychometric theory*. 3rd ed. New York: McGraw-Hill, 1994.
- [28] Sniehotta FF, Schwarzer R, Scholz U, Schüz B. Action planning and coping planning for long term lifestyle change: theory and assessment. *Eur J Soc Psychol* 2005; 35(4): 565-76.
- [29] De Vet E, Oenema A, Brug J. More or better: Do the number and specificity of implementation intentions matter in increasing physical activity? *Psychol Sport Exerc* 2011; 12(4): 471-7.
- [30] Koring M, Richert J, Lippke S, Parschau L, Reuter T, Schwarzer R. Synergistic effects of planning and self-efficacy on physical activity. *Health Educ Behav* 2012; 39(2): 152-8.
- [31] Poobalan AS, Aucott LS, Clarke A, Smith WCS. Physical activity attitudes, intentions and behaviour among 18–25 year olds: A mixed method study. *Bmc Public Health* 2012; 12(1): 640.
- [32] Mok W, Lee AY. A Case Study on Application of the Theory of Planned Behaviour: Predicting Physical Activity of Adolescents in Hong Kong. *J Community Med Health Educ* 2013; 3: 231.
- [33] Ghazanfari Z, Niknami S, Ghofranipour F, Hajizadeh E, Montazeri A. Development and psychometric properties of a belief-based Physical Activity Questionnaire for Diabetic Patients (PAQ-DP). *Bmc Med Res Methodol* 2010; 10(1): 104.
- [34] Ajzen I. Constructing a TPB questionnaire: Conceptual and methodological considerations

2002. Available from: <http://www-unix.oit.umass.edu/~aizen/pdf/tpb.measurement.pdf>.
- [35] Francis JJ, Eccles MP, Johnston M, Walker A, Grimshaw J, Foy R, et al. Constructing questionnaires based on the theory of planned behaviour 2004. Available from: http://pages.bangor.ac.uk/~pes004/exercise_psych/downloads/tpb_manual.pdf.
- [36] Banville D, Desrosiers P, Genet-Volet Y. Translating questionnaires and inventories using a cross-cultural translation technique. *J Teach Phys Educ* 2000; 19(3): 374-87.
- [37] Bazarganipour F, Ziaei S, Montazeri A, Faghihzadeh S, Frozanfard F. Psychometric properties of the Iranian version of modified polycystic ovary syndrome health-related quality-of-life questionnaire. *Hum Reprod* 2012; 27(9): 2729-36.
- [38] Lynn MR. Determination and quantification of content validity. *NURS RES* 1986; 35(6): 382-6.
- [39] Waltz CF, Bausell RB. *Nursing research: Design, statistics, and computer analysis*. Philadelphia: FA Davis Company, 1981.
- [40] Waltz CF, Strickland OL, Lenz ER. *Measurement in nursing research*. Philadelphia: FA Davis company, 1991.
- [41] Polit DF, Beck CT. *Nursing research: Principles and methods*. 46th ed. Lippincott Williams & Wilkins, 2004.
- [42] Lawshe CH. A quantitative approach to content validity. *Pers Psychol* 1975; 28(4): 563-75.
- [43] Lacasse Y, Godbout C, Series F. Health-related quality of life in obstructive sleep apnoea. *Eur Respir J* 2002; 19(3): 499-503.
- [44] Cronbach LJ. Coefficient alpha and the internal structure of tests. *Psychometrika* 1951; 16(3): 297-334.
- [45] Bartko JJ. The intraclass correlation coefficient as a measure of reliability. *Psychol Rep* 1966; 19(1): 3-11.
- [46] Dixon J. *Exploratory factor analysis. Statistical methods for health care research*. London: Lippincott Williams & Wilkins, 2005.
- [47] French DP, Sutton S, Hennings SJ, Mitchell J, Wareham NJ, Griffin S, et al. The Importance of Affective Beliefs and Attitudes in the Theory of Planned Behavior: Predicting Intention to Increase Physical Activity1. *J Appl Soc Psychol* 2005; 35(9): 1824-48.
- [48] Hu Lt, Bentler PM. Cutoff criteria for fit indexes in covariance structure analysis: Conventional criteria versus new alternatives. *Struct Equ Modeling* 1999; 6(1): 1-55.
- [49] Munro BH. *Statistical methods for healthcare research& application of SPSS*

- in data analysis. In: Kazemnejad A, Heidari MR, Norouzadeh R, editors and translators. 1st ed. Tehran: Jamehnegar, Salemi, 2010.
- [50] Robbins LB, Gretebeck KA, Kazanis AS, Pender NJ. Girls on the move program to increase physical activity participation. *Nurs Res* 2006; 55(3): 206-16.
- [51] De Bruin M, Sheeran P, Kok G, Hiemstra A, Prins JM, Hospers HJ, et al. Self-regulatory processes mediate the intention-behavior relation for adherence and exercise behaviors. *Health Psychol* 2012; 31(6): 695.
- [52] Sniehotta FF, Scholz U, Schwarzer R. Action plans and coping plans for physical exercise: A longitudinal intervention study in cardiac rehabilitation. *Brit J Health Psych* 2006; 11(1): 23-37.
- [53] Blue CL. Does the Theory of Planned Behavior Identify Diabetes-Related Cognitions for Intention to Be Physically Active and Eat a Healthy Diet? *Public Health Nurs* 2007; 24(2): 141-50.
- [54] Omondi D, Walingo M, Mbagaya G, Othuon L. Understanding Physical Activity Behavior of Type 2 Diabetics Using the Theory of Planned Behavior and Structural Equation Modeling. *Int J Soc Sci* 2010; 5(3): 1-8.
- [55] Didarloo A, Shojaeizadeh D, Eftekhar Ardebili H, Niknami S, Hajizadeh E, Alizadeh M, et al. Assessment of factors affecting self-care behavior among women with type 2 diabetes in Khoy City Diabetes Clinic using the extended theory of reasoned action. *Payesh* 2011; 11(2): 201-11.
- [56] Tavousi M. Modification of the theory of reasoned action for substance abuse prevention among adolescents [Dissertation]. Tehran: Faculty of Medical Sciences, Tarbiat Modares University; 2009.
- [57] Bozionelos G, Bennett P. The Theory of Planned Behaviour as Predictor of Exercise The Moderating Influence of Beliefs and Personality Variables. *J Health Psychol* 1999; 4(4): 517-29.
- [58] Hosseini M, Khavari Z, Yaghmaei F, Alavi Majd H. Factors related to exercise performance according to Theory of Planned Behavior in female students of Shahid Beheshti University of Medical Sciences. *J Nurs Midwifery* 2010; 19(66): 1-7.
- [59] Ghazanfari, Z. The effectiveness of a theory-based behavior change intervention to increase and maintain physical activity in female diabetic patients in Tehran, Iran [dissertation]. Tehran: Faculty of Medical Sciences, Tarbiat Modares University; 2010.
- [60] Estabrooks P, Carron A. The conceptualization and effect of control beliefs

- on exercise attendance in the elderly. *J Aging Health* 1998; 10(4): 441-57.
- [61] Prapavessis H, Maddison R, Ruygrok P, Bassett S, Harper T, Gillanders L. Using theory of planned behavior to understand exercise motivation in patients with congenital heart disease. *Psychol Health Med* 2005; 10(4): 335-43.
- [62] Pakpour Hajiagha A. Assessment of effectiveness of an educational intervention using the theory of planned behavior, action planning and coping planning to increase and maintain oral self-care behavior in students [Dissertation]. Tehran: Faculty of Medical Sciences, Tarbiat Modares University; 2011.
- [63] Conner M, Sandberg T, Norman P. Using action planning to promote exercise behavior. *Ann Behav Med* 2010; 40(1): 65-76.
- [64] Hagger M, Chatzisarantis N, Biddle S. A meta-analytic review of the theories of reasoned action and planned behavior in physical activity: Predictive validity and the contribution of additional variables. *J Sport Exercise Psy* 2002; 24(1): 3-32.
- [65] Biddle S, Nigg C. Theories of exercise behavior. *Int J Sport Psychol* 2000; 31(2): 290-304.
- [66] Fishbein M, Ajzen I. Belief, attitude, intention and behavior: An introduction to theory and research. 1st ed. USA: Addison-Wesley, 1975.